

DriTec 150

(Models: F212, F212-230V, F212-230V UK, F212-GRN)

Symbol Definition

- * - multiple components to choose from for different models: voltage, size, color, etc.
- + - if you order this item, you may need to order additional items marked with same number of +'s in order to upgrade or complete repair

#	Part Description	Specifications/Model	Part #	Qty
	Wire	Red 14GA Awm 105c/600v (14")	02-00099	ft. 1.17'
	Wire	White 14Ga AWM 105c/600v (28")	02-00101	ft. 2.33'
	Wire	Black 14Ga AWM 105c/600v (28")	02-00102	ft. 2.33'
	Wire	White 18Ga Awm 105c/600v (14")	02-00104	ft. 1.17'
	Wire	Black 18Ga Awm 105c/600v (14")	02-00105	ft. 1.17'
	Connector		02-00133	ea. 2
	Connector	Qc .250 Fem Fully Insul 16/14 Ga	02-00135	ea. 10
59	Terminal Block	6 x 6 x 8 x 4	02-00157	ea. 1
72	Motor, Drive	115v, 1.8 RPM (<i>for 230V, use 02-00118</i>) Use new pulley & w	02-00176	ea. 1
60	Capacitor *	115v, 6MFD 370v w/Mtg Brkt	02-00181	ea. 1
102	Strain Relief	Snap	02-00218	ea. 1
	Connector	Qc .187 Fem Fully Insul 22/18 Ga	02-01448	ea. 2
	Switch	Switch-Rocker spst 115v Red W/Splash Grd	02-01471	ea. 1
27	Washer	1/4"	03-00001	ea. 16
46	Spacer	Nylon, 1" Dia Tube	03-00009	ea. 4
	Cable Tie	Nylon, 4"	03-00012	ea. 5
34	Washer	3/16"	03-00013	ea. 8
35	Nut	Nyloc 8-32	03-00015	ea. 4
30	Nut	Nyloc 1/4-20	03-00017	ea. 4
77	Screw	#8 x 1/2	03-00020	ea. 13
10	Rivet	1/4 Steel	03-00022	ea. 16
62	Screw	#8 x 1/2 Pan Phil	03-00023	ea. 2
98	Nut	1/4-20 Nylon Insert Thin	03-00029	ea. 2
9	Rivet	1/8 Alum.	03-00036	ea. 2
22	Nut	10-24 w/Starwasher Zp	03-00038	ea. 8
16	Gasket	3/8 x .06 Clsd Cell Neoprene/Ploy (13.6")	03-00049	ft. 4.98'
15	Gasket	3/8 x .06 Clsd Cell Neoprene/Ploy (13.6")	03-00049	ft. 4.77'
8	Gasket	3/8 x .06 Clsd Cell Neoprene/Ploy (13.6")	03-00049	ft. 1.13'
7	Gasket	3/8 x .06 Clsd Cell Neoprene/Ploy (20.5")	03-00049	ft. 1.71'
6	Gasket	3/8 x .06 Clsd Cell Neoprene/Ploy (20.5")	03-00049	ft. 1.71'
5	Gasket	3/8 x .06 Clsd Cell Neoprene/Ploy (13.6")	03-00049	ft. 1.13'
110	Bushing	Split Black, Rubber	03-00050	ea. 2
44	Knob	Star w/ 1/4 x 20 Insert Blk Top In	03-00056	ea. 2
14	Washer	5/16" Zp	03-00062	ea. 4
25	Washer	5/16 Lock Zp	03-00063	ea. 2
13	Collar	20mm Shaft, 1 PC Clamp Stl	03-00065	ea. 1
	Clamp	Hose 4"SS, Worm Drive	03-00070	ea. 2
47	Bolt	Carriage 1/4-20 x 2 1/4	03-00072	ea. 2
12	Washer	.75" ID x 1.125" OD x .125 Tef	03-00077	ea. 1

#	Part Description	Specifications/Model	Part #		Qty
48	Screw	#10-24 x 3/8	03-00091	ea.	8
40	Screw	#10-24 x 1" Zp	03-00093	ea.	8
24	Bolt	Hex 5/16-18 x 1 GR 5 Zinc	03-00099	ea.	2
54	Clamp	Hose 12" Worm Drive	03-00125	ea.	1
69	Bushing	.671 x .875 x .41 Nylon Blk	03-00126	ea.	1
70	Screw	8-32 x 3/4 HH Zp	03-00133	ea.	4
28	Bolt	Hex 1/4-20 x 3/4 Zinc	03-00139	ea.	4
31	Rivet	3/16 x 1/4 St/St Blk, SB6-4	03-00432	ea.	21
20	Nut	Nyloc 10-24 Zp	03-00491	ea.	7
51	Pin	Hitch #17	03-00501	ea.	2
52	Washer	1 1/4 x 1/2 x .062	03-00502	ea.	6
49	Bolt	Oval Phil Mach 1/4-20 x 1 1/2	03-00503	ea.	4
56	Rivet	1/8 x 1/8 Al/Al	03-00901	ea.	4
84	Screw	Hwh Class 2 TF 8-32 x 1/4	03-00962A	ea.	9
36	Washer	Rivet 5/32 "	03-01333	ea.	5
61	Rivet	5/32" x 1/2 Al/Al Blk Anodized	03-01367	ea.	1
21	Screw	10-24 x 1/2 Slot Zp	03-01429	ea.	4
	Foam Wrap	6" x 6" Perf. White 850 Pcs Per Roll	06-00035	ea.	2
	Insert Foam	Bottom, 15.5" x 10.5" x 5.5"	06-00043	ea.	1
	Foam	2.75" x 2.75" x 21" EPS 1Lb	06-00048	ea.	2
	Bag	9" x 15" Poly	06-00056	ea.	1
	Box	21.625" x 21.625" x 33"	06-00081	ea.	1
99	Label	Product	07-00280	ea.	1
100	Label	Operating Instructions	07-00281	ea.	1
117	Label	Caution Y/B Dehumidifier	07-01432	ea.	1
45	Leg	Pc Wr Blk	08-00126	ea.	2
109	Power Cord Assembly	230v, 25Ft (F212-230v)	08-00200	ea.	1
106	Power Cord Assembly	230v UK, 25Ft (F212-230v UK)	08-00201	ea.	1
101	Power Cord Assembly	115v, 25Ft (F212, F212-GRN)	08-00203	ea.	1
71	Tensioner	Belt Tensioner	11-00019	ea.	1
75	Tape	2" x 5 Mil Teflon PSA (5")	11-00081	ft.	0.42'
11	Axle	Rotor	11-00045	ea.	1
96	Seal	60 DUR Extrd Silicon Red (9.5")	11-00056	ft.	0.78'
94	Seal	60 DUR Extrd Silicon Red (5.5")	11-00056	ft.	0.46'
92	Seal	60 DUR Extrd Silicon Red (5")	11-00056	ft.	0.38'
81	Seal	60 DUR Extrd Silicon Red (5")	11-00056	ft.	0.42'
78	Seal	60 DUR Extrd Silicon Red (4.5")	11-00056	ft.	0.37'
74	Seal	60 DUR Extrd Silicon Red (5")	11-00056	ft.	0.42'
53	Seal	Extruded Silicon 60 Dur Red, (39")	11-00056	ft.	3.03'
19	Filter	8.28" x 8.16" x 1.88" 25 Ppi Blk	11-00074	ea.	1
26	Insulation	3.5" ID x .5" Wall	11-00075	ft.	0.29'
95	Tape	2" x 5 Mil Teflon PSA (6")	11-00081	ft.	0.46'

#	Part Description	Specifications/Model	Part #		Qty
93	Tape	2" x 5 Mil Teflon PSA (5")	11-00081	ft.	0.38'
82	Tape	2" x 5 Mil Teflon PSA (5")	11-00081	ft.	0.42'
79	Tape	2" x 5 Mil Teflon PSA (5")	11-00081	ft.	0.37'
75	Tape	2" x 5 Mil Teflon PSA (5")	11-00081	ft.	0.41'
73	Pulley	1/2" Timing Belt 3/8" Pitch, 18 Teeth	11-00143	ea.	1
85	Axle	Zp	11-00151-01	ea.	1
33	Base Assy	Pc Wr Blk	11-00152-01	ea.	1
38	Blower Assy **	115v, Curve 100W 3250RPM, 1 Speed	11-00153	ea.	1
37	Blower Mount	Zp	11-00154-01	ea.	1
58	Bulk Head	Bulk Head, Stl	11-00155	ea.	1
23	Cord Wrap	Nc Stl	11-00156-01	ea.	1
39	Cover ***	Fisher Blue	11-00157-01	ea.	1
4	Duct Ring	4" Diameter, ABS Blk.	11-00158	ea.	5
18	Filter Frame	Blk	11-00159-01	ea.	1
1	Panel	Fisher Blue, Front	11-00160-01	ea.	1
83	Cover	Heater Box	11-00161	ea.	1
76	Seal Strip	Heater Box Cover	11-00162	ea.	2
66	Insulation	Front 1/2" Marinite	11-00163	ea.	1
67	Insulation	Front Bottom, 1/2" Marinite	11-00164	ea.	1
68	Insulation	Front Side, 1/2" Marinite	11-00165	ea.	2
64	Insulation	Front Top, 1/2" Top Marinite	11-00166	ea.	1
80	Insulation	Rear Bottom, 1/2" Marinite	11-00167	ea.	1
90	Seal Strip	React Plenum Top	11-00168	ea.	1
107	Blower Assy **	230v, 100w,2850RPM, 1 Speed	11-00169	ea.	1
89	React Plenum Assy	React Plenum Assy	11-00170	ea.	1
17	Panel	Rear, Blk	11-00171-01	ea.	1
55	Rotor	290MM x 100MM	11-00172	ea.	1
32	Drive Belt	48 x 1/2 x 3/8 Pitch	11-00173	ea.	1
97	Seal Strip	React Plenum spring	11-00174	ea.	1
	Wire Harness	115v/230v, Complete	11-00175	ea.	1
43	Handle	Black	11-00176-01	ea.	1
63	Heater Assembly	PTC 120v, 60 HZ 1.5 KW w/Housing	11-00177	ea.	2
65	Heater Box	Heater Box, Stl	11-00178	ea.	1
86	Divider	Right Heater Box	11-00179	ea.	1
88	Bracket	Support	11-00180	ea.	1
108	Heater Assembly	230v, 50Hz, w/ Housing	11-00181	ea.	2
87	Divider	Left Heater Box	11-00182	ea.	1
91	Seal Strip	React Plenum Bottom	11-00183	ea.	1
112	Inlet Ring	Blower 7.50 Diameter, Galv Stl.	11-00185	ea.	1
3	Meter, Hour	Hour 115/230v	12-00929	ea.	1
	Ducting, Yellow	4" Dia x 20 Ft Lg, Yellow w/Black	13-00017	ea.	1
	Insulation	.875 ID x .5 Wall x 6Ft	13-00115	ea.	2
42	Rubber Tip	Black Rigid Handle	13-00510	ea.	2
50	Wheel	9" x 1/2" Bore Black	13-00861	ea.	2
111	Cap	Vinyl, .375 ID x 1"	13-01056	ea.	2
41	Plug	Metal End, 1"	13-01190	ea.	4

DriTec 150 Pictorial Drawing

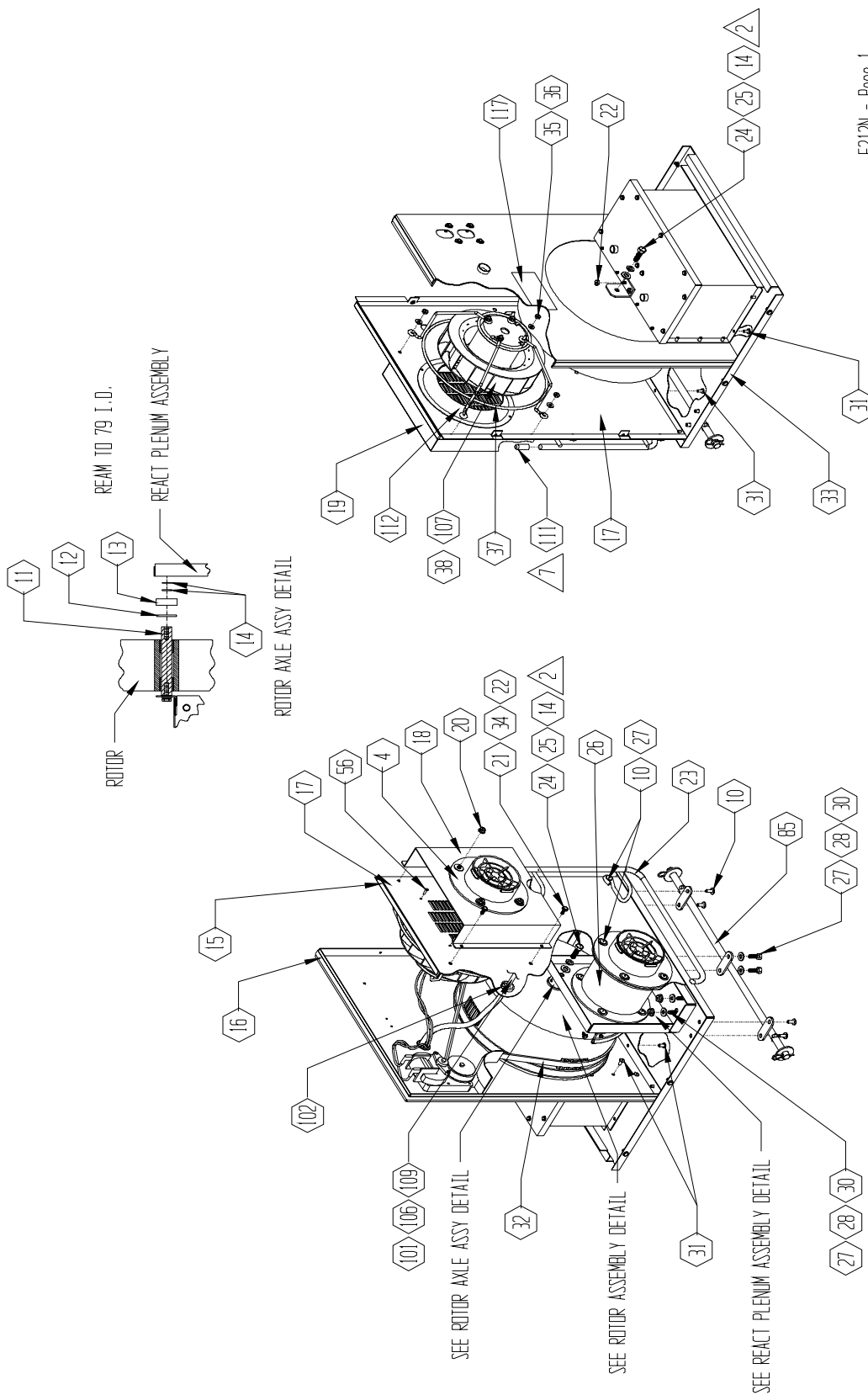

F212N - Page 1

DriTec 150 Pictorial Drawing

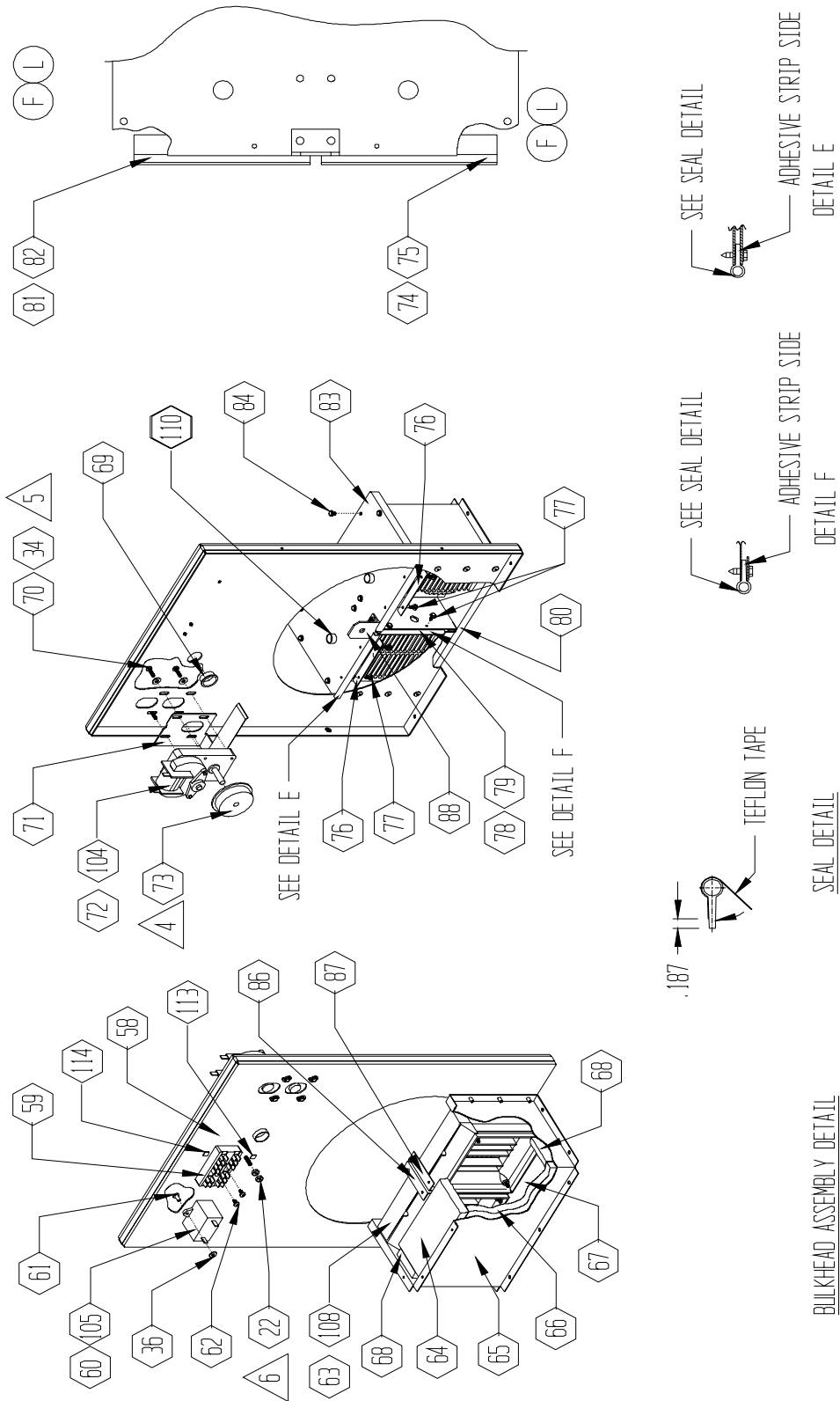

F212N - Page 2

DriTec 150 Pictorial Drawing

F212N - Page 3

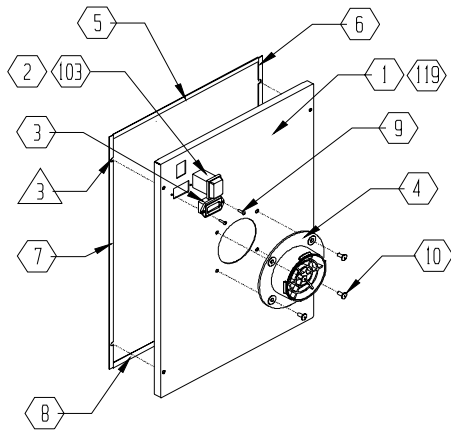

FRONT PANEL ASSEMBLY DETAIL

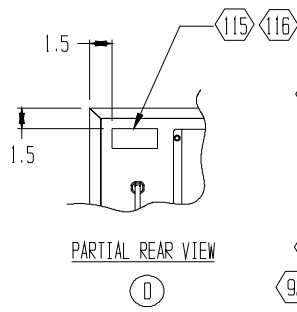

PARTIAL REAR VIEW

Ⓚ



ADHESIVE STRIP SIDE

DETAIL B

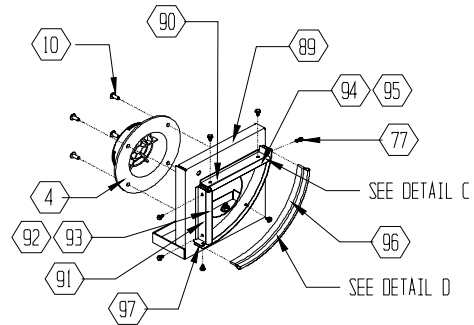

REACT PLENUM ASSEMBLY DETAIL

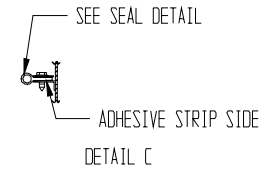

DETAIL C

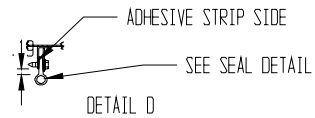

DETAIL D

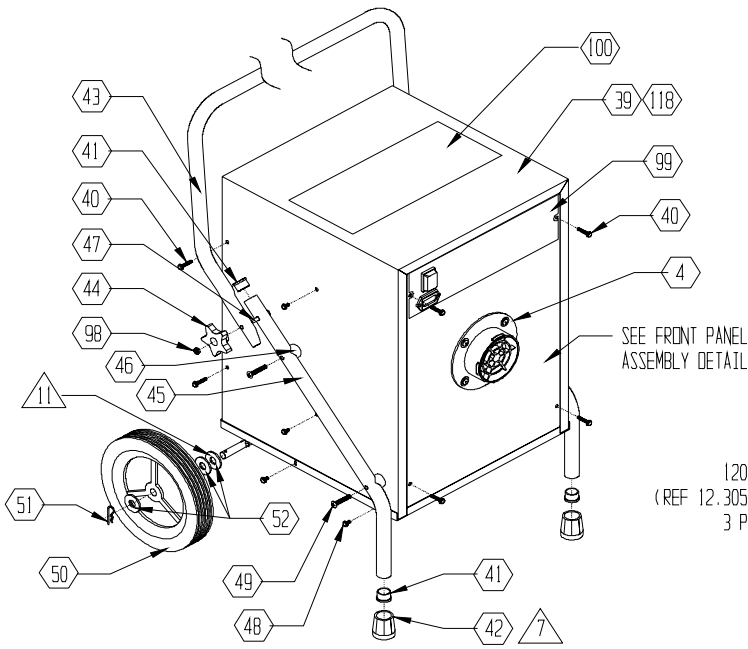

SEE FRONT PANEL ASSEMBLY DETAIL

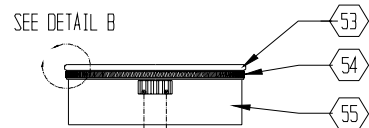

SEE DETAIL B

120.00°
(REF 12.305 ARC LENGTH)
3 PLCS

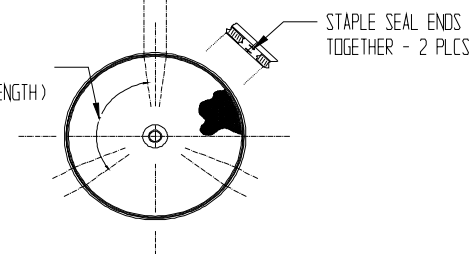

ROTOR ASSEMBLY DETAIL

